

JOURNAL OF BUILDING AUTOMATION



Issue
23

BACnet
TESTING & CERTIFICATION

A PUBLICATION BY:



BACnet
International



Continually Raising Building Standards

BACnet International is an industry association that facilitates the successful use of the BACnet protocol in building automation and control systems through interoperability testing, educational programs and promotional activities.



BACnet is leading the world in Building Protocol Standard: It plays a significant role in building automation projects worldwide.



Achieving the Mark of Distinction: The BACnet Testing Laboratories (BTL) Mark provides users with assurance that a product has passed the industry standard BACnet conformance tests conducted by a recognized, independent testing organization. The BTL Mark is a mark of distinction, achieved by more than 1300 products, that many building owners and control system designers look for as a must-have in order to be eligible for a project.

► Discover More Today: bacnetinternational.org

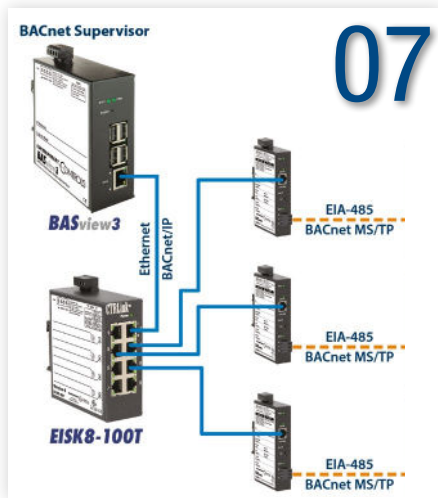

07

© Contemporary Controls

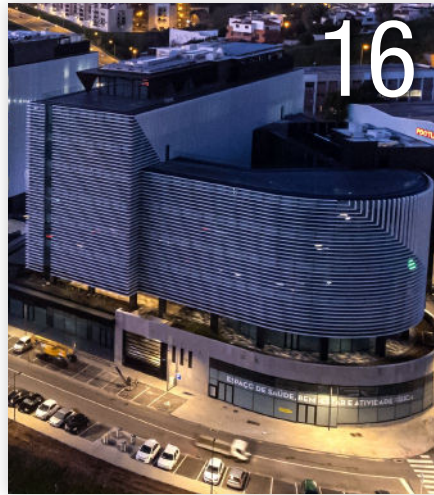

16

© Delta Controls Germany



24

© BACnet International

Feature Articles

Letter from the President	5
Energy Savings using Communicating Thermostats	6
BTL Certification Overview	8
How to Get Your BACnet Product Tested	10
Why Specify the BTL Mark?	12
HVAC Integration in Context of Energy Savings	14

Success Stories

Canada's First Zero Carbon Office Building	15
Exemplary Energy Efficiency and Tenant Friendliness Combined	17
Water to Air Solutions Applied to Skyscrapers with BACnet	18
Flexible, Sustainable Solutions for the Working World at Axel Springer	19

Departments

New to the BACnet International Family	20
New BACnet Cybersecurity Acceleration Program	22
BACnet International at the 2023 AHR Expo	24
Expand Your BACnet Knowledge	25

BACnet International News

BACnet Testing Laboratories (BTL) Testing Updates	26
New BTL-Listed Products	28
Calendar of BACnet International Events	30
Legal Notice	31



Cover picture:
©Evolv

Content
Issue 23 | May. 2023

All issues can be downloaded from
bacnetinternational.org/journals

Coming soon

BACnet Cybersecurity Acceleration Program

With the phenomenal success of the BACnet Secure Connect Interoperability Acceleration Program, BACnet International would like to invite you to the next phase of BACnet cybersecurity.

The first stage of this new program focuses on providing you with the knowledge and tools to add interoperable network configuration to your solutions. The second stage provides guidance and tools to understand and implement certificate management. Fast track your in-house technical knowledge and development with:

- ◇ Early access to the reference implementations
- ◇ Access to technical forums monitored by industry experts
- ◇ Access to multiple webinars
- ◇ Access to multi-vendor testing
- ◇ Source code licensing
- ◇ Participation in ongoing development of the Manufacturer's BAS Cybersecurity Guidelines

For more information, contact Membership and Education Manager David Nardone at david@bacnetinternational.org



Letter from the President

What is BACnet?

Dear Reader,

For more than 30 years people have asked the question, “What is BACnet?” and the answer to that question has changed over the years. Initially, the answer was that BACnet is “a dream,” where equipment from all manufacturers interoperates without the need for custom drivers or integration software. As BACnet has grown and evolved from its initial release over these many years, the answer to that question has evolved with it. It has gone from “a dream” to “a protocol” to “a global standard” to “an integration platform” and all the way back to “a dream” again. Interestingly, all of those answers are still valid.

BACnet began as a dream shared by a small group of people. The dream was of a building automation industry where users could specify equipment from any manufacturer and expect it to interoperate with equipment from any other manufacturer. This group rightly concluded that the path to transforming the dream into reality started with the development of a communications protocol designed to address the broad requirements of building automation. When BACnet was released in 1995 it was promoted as a communication protocol and was often defined through a comparison with other communication protocols. But that only lasted for a while.

BACnet became an international standard in 2004 and was widely adopted around the world. It became the most broadly specified protocol for building automation globally around 2012. An independent market study in 2017 showed a global market penetration of 64% (and more recently, a 2022 update showed that number had grown to 77%). As a result, BACnet became known as the global standard for building automation. But, the answer to the question “What is BACnet?” did not stop there.

BACnet-based products have continued to evolve to provide connectivity across devices and subsystems with standard messaging and data representations. As a result, in our interconnected, data-driven world, BACnet has become known as the integration platform for intelligent buildings. It enables building automation specifiers and integrators to unlock the full environmental, social and economic benefits of continuously optimized building systems.

Which brings us all the way back to “dreams,” because we now dream of a world where connected, intelligent buildings are the norm and support the development of smart cities. Cities that are better for their residents, their stakeholders, and the planet. So, the question “What is BACnet?” is multi-faceted now. BACnet is a protocol, it is a global standard, it is an integration platform. It is a dream fulfilled and it is also a dream of an even better future. With the broader scope of this new Journal, we look forward to sharing with you information and ideas about that future as it evolves. 🌍



© McMillan

Andy McMillan
President and Managing Director BACnet International
andy@bacnetinternational.org | www.bacnetinternational.org



ABOUT THE AUTHOR

Andy McMillan is President and Managing Director of BACnet International, where he works with users and suppliers to expand and enhance the BACnet community. Previously he served as President of a building automation and energy management business unit of Philips Lighting.

Energy Savings using Communicating Thermostats with BACnet Supervision

The building automation industry is working to develop sustainability and energy savings solutions in building management systems. Large buildings have a BMS that controls all aspects of the occupant comfort, including temperature and indoor air quality. This involves monitoring and controlling a multitude of devices—boilers, chillers, VAVs, VFDs and Air Handling Units (AHUs). Most of the small and medium-size buildings don't have a BMS because of the perceived complexity, but there is an easy way to introduce automation which will improve sustainability and energy savings.

A small/medium building is typically divided into multiple zones, with each zone having its own Rooftop Unit (RTU) controlled by a stand-alone thermostat for staged heating or cooling. These thermostats are usually configured once, and the occupant changes the setpoint to lower or raise the temperature for their desired comfort level. Non-communicating thermostats typically have a setback feature with a weekly schedule so they could provide energy savings but don't provide an easy way to accommodate schedule changes or to monitor them from a single location. This could lead to a change made for a holiday that is never changed back to the original settings. They do not have any centralized supervision with a building-wide schedule. A central BACnet supervisor can provide better scheduling, performance dashboards, and simple trend

data. Updating these thermostats with BACnet communicating thermostats with a supervisor is an easy step towards automating small and medium sized buildings.

Using BACnet/IP Thermostats

A BACnet/IP communicating thermostat that supports Wi-Fi is a quick non-invasive replacement to add some automation. Depending on the space, a single access point may provide wireless coverage to connect all the Wi-Fi stats to the network, otherwise multiple access points can be used.

The Wi-Fi access point routes the wireless signal from the thermostat carrying BACnet/IP messages to a wired Ethernet switch which provides BACnet/IP to the BACnet supervisor over a wired Ethernet connection. The number of Wi-Fi clients supported by the access point depends on distance and Wi-Fi access point performance.

Setting Up the BACnet Supervisor

The BACnet supervisor can discover the BACnet thermostats and their associated points. The thermostats' occupied cooling/heating and unoccupied heating/cooling setpoints can be written via BACnet. Schedules can be implemented in the supervisor, and they can

all vary between the building zones per their different occupied times. The supervisor can also provide diagnostic information which can be used to setup alarm conditions in the supervisor and send alerts via email.

Additional supervisory features include animated graphic screens, scheduling, historical trending, runtime accumulation and email alarms. The supervisor will automatically change setpoints on schedule, collect runtime and trend data, and monitor alarm conditions.

To create graphics and dashboards, images, such as floor plans, mechanical equipment, and zone layout, can be uploaded to the supervisor. Then, animated graphical elements, such as gauges, buttons, and labels, can be positioned on top of the image to give users insight and control for adjusting parameters, such as setpoint or occupancy state. A supervisor supports multiple logins with different user permission levels allowing users to create dashboards and graphics for both the service personnel who maintain the HVAC equipment, and the end users/occupants who are interested in comfort parameters.

BACnet Supervisor

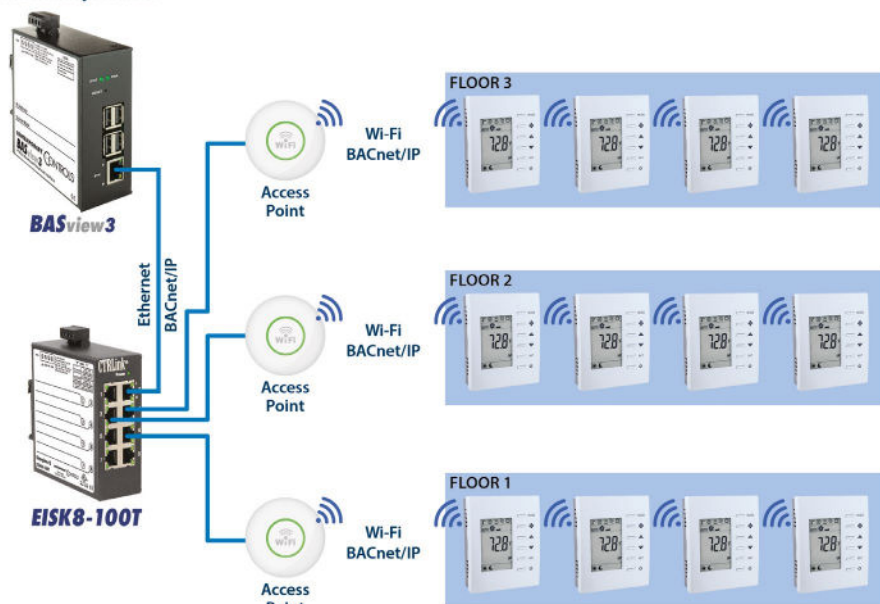

BACnet/IP Wi-Fi Thermostat Network
©Contemporary Controls

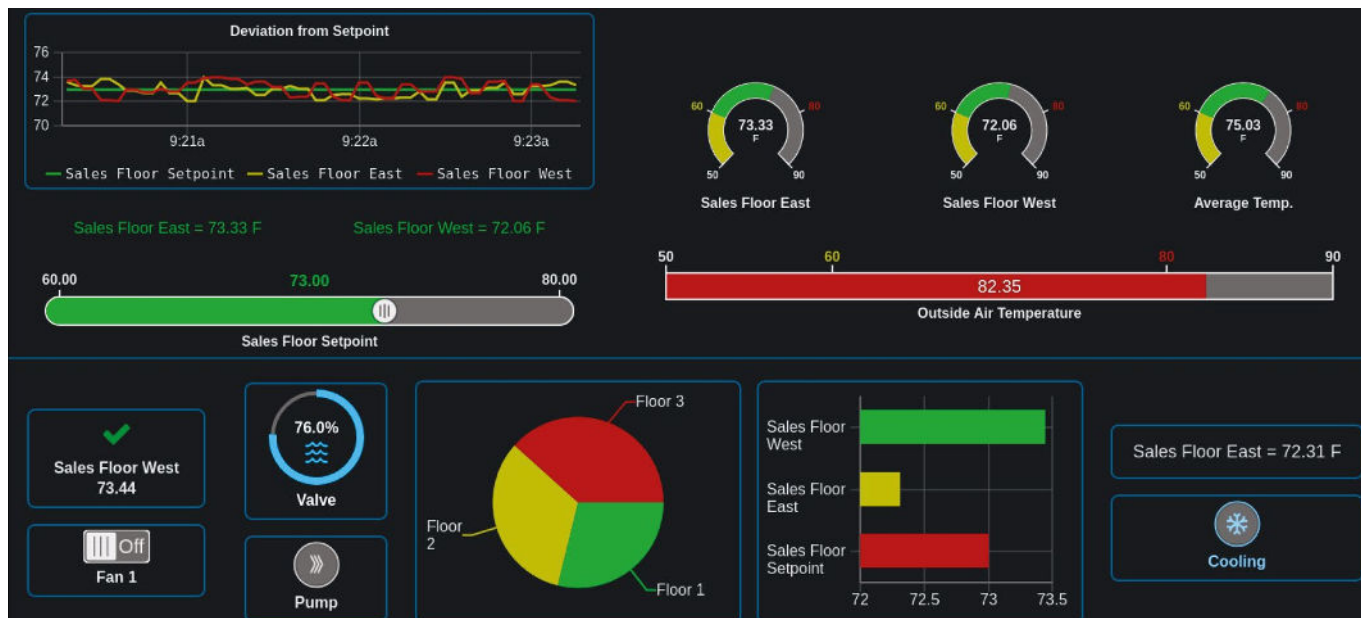

BACnet Supervisor dashboard showing trends and current data ©Contemporary Controls

Connecting a Display Unit

A laptop and web browser can be used to view the supervisor dashboard if the owner only wants to see data occasionally. A wall-mounted display, such as an Android Screen, can be connected to the network to allow easy access to the dashboard. The display unit can be mounted to a central location either over Ethernet or Wi-Fi. A display with a PoE option can supply both power and network connectivity over a single Ethernet cable.

Using BACnet MS/TP Thermostats

If Wi-Fi is not an option, BACnet MS/TP thermostats can easily be networked together in a daisy-chain with a single-pair cable. The thermostats can then be connected to a BACnet supervisor over MS/TP. To install the BACnet supervisor over the existing Ethernet infrastructure, a BACnet/IP to MS/TP router can be used to connect the BACnet/IP supervisor to the thermostat MS/TP network. The supervisor can monitor the current temperature, setup schedules with holiday exceptions as well as send alarms.

Conclusion

This small building automation setup lends itself well to future enhancements to expand the BACnet network with more controls. Depending on the condition and anticipated lifetime of the RTU, an economizer can be added to the RTU for better indoor air quality and free cooling options. Communicating BACnet thermostats are available for Fan Coil Units (FCU) and Heat Pumps allowing this concept to be implemented for additional equipment types. Once a building owner sees the energy savings and benefits of building automation, they will be open to expand the system.

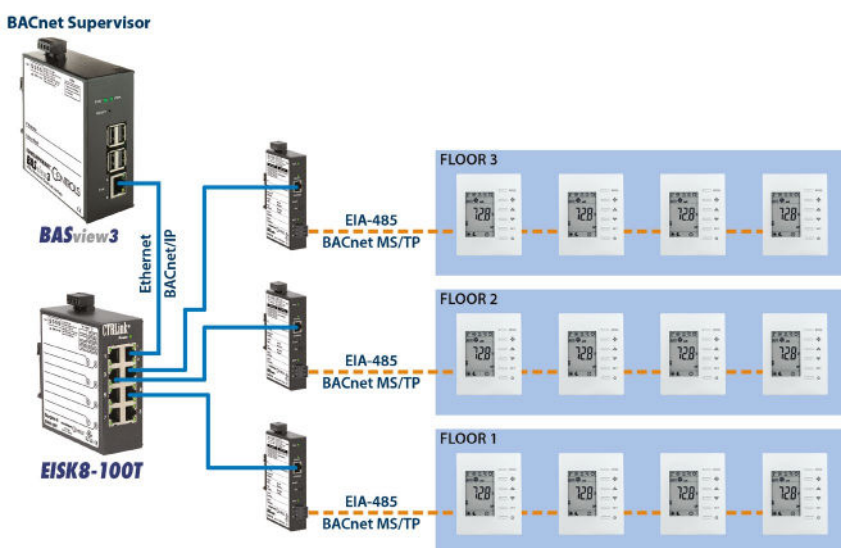

BACnet MS/TP Thermostat Network ©Contemporary Controls

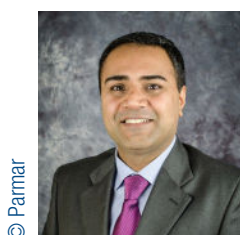

Harpartap Parmar
 Director of Product Management | Contemporary Controls
 hparmar@ccontrols.com | www.ccontrols.com



ABOUT THE AUTHOR

Harpartap Parmar is a Director of Product Management at Contemporary Controls, which designs and manufactures BACnet building controls and networking equipment. Parmar focuses on network security, IP routers and their application to Building Automation. He has over 22 years of experience at Contemporary Controls with range of networking, control, and communication products.

BTL Certification Overview

BACnet is the global standard for interoperable building automation solutions, and it works best when all products in a system are correctly implemented. Ensuring products are correctly implemented is the mission of The BACnet Testing Laboratories (BTL) Certification program.

The Three Parts of a BTL Certification

There are three elements to BTL Certification: BTL Listing, BTL Certificate, and the BTL Mark.

The BTL Listing indicates that BACnet functionality in each Listed product has been successfully tested at a Recognized BACnet Testing Organization (RBTO) utilizing the industry standard BTL test suite and test policies that were current at the time it was tested. The BTL Listing identifies several specifics about what BACnet functionality was tested:

- BACnet Device Profile
- BIBBs supported
- BACnet Object Types
- Data Link Layers

For Listings with multiple products, some products may have less functionality than is indicated by the Listing document. The PICS (Protocol Implementation Conformance Statement) document (provided by the manufacturer) provides information on the specific functionality of each product.

The BTL Mark may only be used for products that have a valid BTL Listing. The BTL Certificate is an additional certificate of compliance required by some European countries. However, the BTL Certificate is becoming more widely accepted in the building automation controls market.

How do I get a BTL Certification?

BTL Certification begins with BTL Testing at a Recognized BACnet Testing Organization. The manufacturer provides a complete and accurate BTL Checklist that identifies all the BACnet functionality of a product. The BTL Checklist is part of the BTL Test Package found on the Test Documentation page of the BTL website: btl.org/testing-documentation.

A list of Recognized BACnet Testing Organizations and their contact information is found on the Device Testing page of the BTL website: btl.org/device-testing.

BTL recommends comprehensive pre-testing before a manufacturer enters BTL Testing. This will save the manufacturer time and money during the testing process. Information concerning BTL Testing is found on the Test Documentation page. Additional information about Testing Resources is found on the Testing Resources page of the BTL website: btl.org/testing-resources/

When BTL Testing has been successfully completed, the RBTO will issue a Final Test Report. This report will be sent to the manufacturer in both testreport.pdf and testreport.xlsx formats. These documents are required when applying for a BTL Certification.

Apply for a BTL Certification: btl.org/certification-application/

The documents required for a BTL Certification are:

- Both test reports
- PICS as specified by the BACnet Committee: bacnet.org/conformance-pics/
- BTL Listing and Certification Agreement – The BTL Certifications and Listings Manager will provide this if there is not one already on file.

BACnet International corporate members may also choose to provide:

- Image of the product
- Product description

For derived products (see BTL Testing Policies for details btl.org/testing-documentation/), an attestation form will be required. The BTL Certifications and Listing Manager will provide guidance on what information is required in each case.

Once all the documentation is received and reviewed, the request for BTL Certification is transferred to the BTL Certifier, an independent organization specifically certifying the product's conformance to the BACnet standard and fulfillment of the requirements of the BACnet test standard, as laid out in the BTL Testing Policies.

A BTL Listing is valid for 25 years, from test completion, for B-SS and B-SA products. It is valid for 15 years, from test completion, for all other device profiles. The company holding the BTL Listing must maintain listing fees and maintenance of the product for the BTL Listing to remain valid.

A BTL Certificate is valid for 5 years, from test completion, with the same requirements for fees and maintenance. A BTL Certificate may be renewed with minor additional testing, as defined in the BTL Testing Policies.

What about a Re-Branded Product?

Many companies re-brand a product, either under a separate label within the original company or as an OEM to other companies. The process is the same with some minor exceptions to the documentation required.

The documents required by the re-branding company for BTL Certification are:

- Original manufacturer's BTL Listing document
- PICS as specified by the BACnet Committee: bacnet.org/conformance-pics/
- BTL Listing and Certification Agreement – The BTL Certifications and Listings Manager will provide this if there is not one already on file.

BACnet International corporate members may also choose to provide:

- Image of the product
- Product description

A BTL Certification for a manufacturer and a BTL Certification for a re-branding company appear exactly the same on the BTL Listing pages.

For additional information, visit the BTL website, btl.org, or contact the BTL Certifications and Listings Manager, at certifications@bacnetinternational.org.

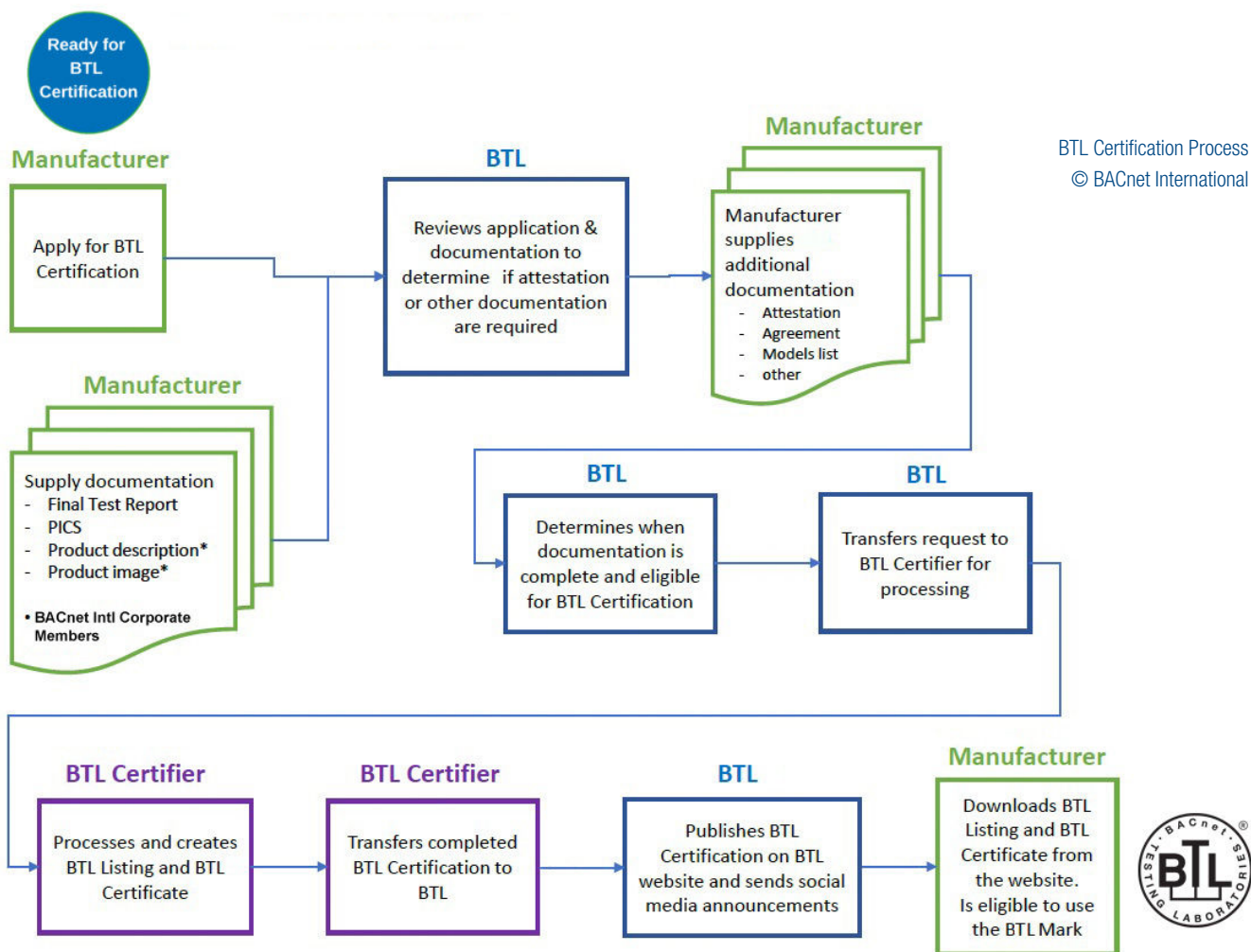

ABOUT THE AUTHOR

Emily Hayes began work with BACnet International in 2014 as BTL-Coordinator, coordinating BTL Testing at the BTL Lab. In 2017, Emily took over leadership of the BTL Working Group as chair. Additionally, she led the transition from the BTL Listing Program to the BTL Certification Program. She became BTL Manager in January 2019.

Emily maintains professional membership in the Project Management Institute (PMI), North Carolina Chapter of PMI (NCPMI), and Institute of Electrical and Electronics Engineers IEEE.

Emily has a BEE from Auburn University and an MSEE from Duke University. She has maintained a Project Management Professional (PMP) Certification since 2010.

© Hayes



Emily Hayes
BTL Manager, Certifications and Listings Manager and BTL Working Group Chair
btl-manager@bacnetinternational.org | www.bacnetinternational.org



How to Get Your BACnet Product Tested

You have a BACnet product and want to ensure it has the protocol implemented correctly, saving you time and money in the field. Also, customers and integrators in your market are requiring that any BACnet product on their specification be BTL certified. What to do? The first step in this process is getting your BACnet product tested.

BACnet conformance testing is conducted by several Recognized BACnet Testing Organizations (RBTOs) around the world in accordance with testing policies developed and maintained by BACnet Testing Laboratories (BTL). The RBTOs perform tests to validate that products have correctly implemented the BACnet protocol. Successful test results from the RBTOs can then be used as the basis for BTL Certification.

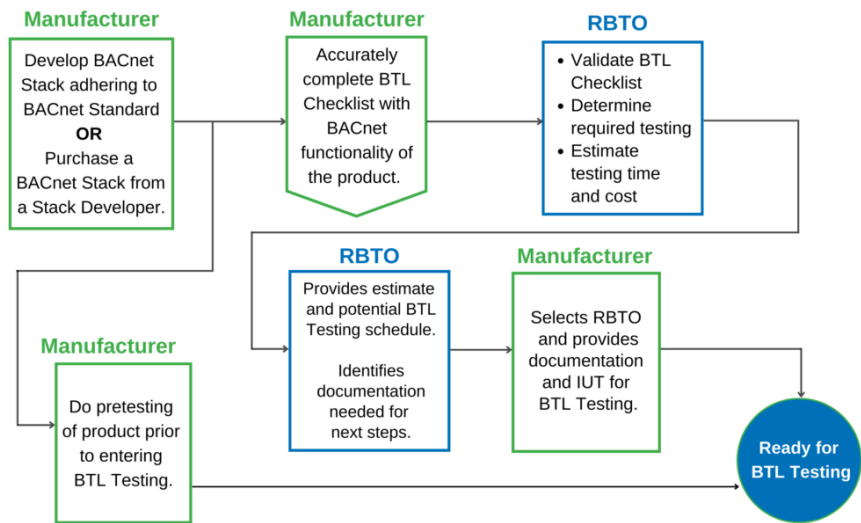

Process for preparing for BTL Testing
© BACnet International

Pre-Testing

Besides saving time and money during conformance testing, manufacturers are required to extensively pre-test their products prior to submission to an RBTO. The RBTO is not a quality assurance lab. Products need to be ready for market when submitted.

There is a range of resources focused on the development of BACnet products available to BACnet developers and manufacturers. An extensive list of these can be found on the [Pre-Testing Tools](#) page of the BTL website. Additionally, the BTL Test Package, found at [btl.org/testing-documentation](#), is available to developers for their own internal pre-testing. The BTL Test Package contains all the tests and requirements that are currently being used at the RBTOs.

Recognized BACnet Testing Organizations

Testing at RBTOs is conducted according to the requirements of the BTL Working Group (BTL WG). These requirements can be found in the BTL Testing Policy found on the BTL website at

[btl.org/testing-documentation](#). Manufacturers indicate a device's BACnet functionality by completing the BTL Checklist, included in the BTL Test Package. The RBTO then creates a test plan that specifies which tests will be run on the device.

Once testing has been successfully completed, the manufacturer will receive a final test report which is used for BTL Certification.

Tips for a Successful Testing Experience

While the RBTO estimates the time required to perform the testing of each device, they make some assumptions that are key to completing testing successfully.

The BTL testing performed is for the compliance of the BACnet implementation; it does not include any development testing. Assumptions made by the RBTO include:

- The manufacturer has fully completed development of their product and all internal pre-testing of the product prior to submitting it for BTL Testing. To help ensure successful RBTO testing, the manufacturer can review pre-testing tools at [btl.org/pre-testing-tools](#).

- The manufacturer provides instructions on how to setup their device to perform each test, related to their functionality, defined in the current BTL Test Package. These instructions will assist the RBTO with the setup and execution of the required tests and will keep time and costs to a minimum during testing. The RBTO will request that these instructions are submitted using the IUT Special Instructions document prior to the start of testing a product. This document is part of the Test Package found at [btl.org/testing-documentation](#).

More Information

For additional information on testing, including a list of available RBTOs, visit the [Device Testing page](#) on the BTL website. If you have any questions on BTL testing or the testing process, contact Emily Hayes, BTL Manager at btl-manager@bacnetinternational.org. Details of the specific RBTO's process and testing documentation can be obtained by contacting the RBTO directly.

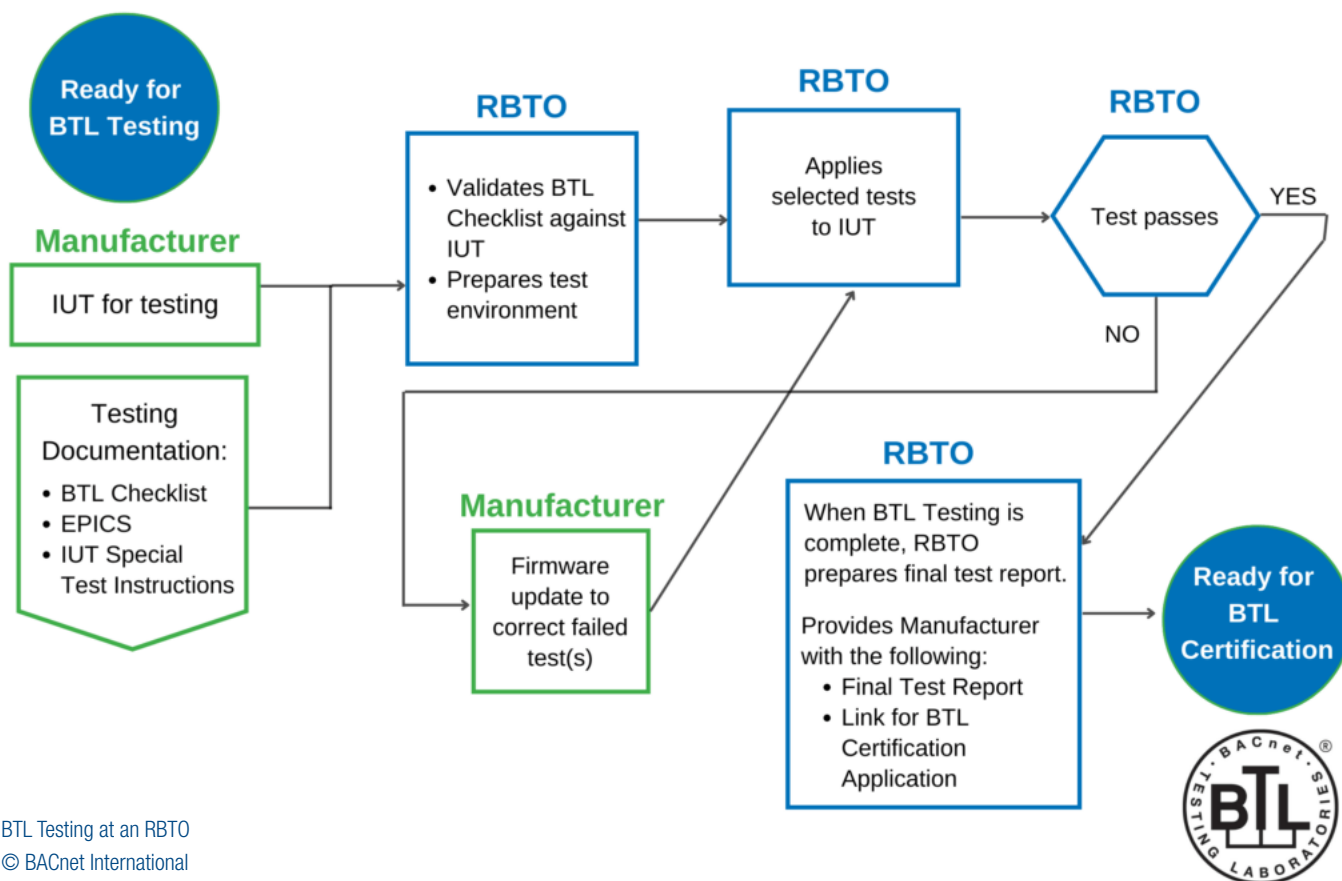

BTL Testing at an RBTO
© BACnet International



ABOUT THE AUTHOR

Emily Hayes began work with BACnet International in 2014 as BTL-Coordinator, coordinating BTL Testing at the BTL Lab. In 2017, Emily took over leadership of the BTL Working Group as chair. Additionally, she led the transition from the BTL Listing Program to the BTL Certification Program. She became BTL Manager in January 2019.

Emily maintains professional membership in the Project Management Institute (PMI), North Carolina Chapter of PMI (NCPMI), and Institute of Electrical and Electronics Engineers IEEE.

Emily has a BEE from Auburn University and an MSEE from Duke University. She has maintained a Project Management Professional (PMP) Certification since 2010.

© Hayes



Emily Hayes
BTL Manager, Certifications and Listings Manager and BTL Working Group Chair
btl-manager@bacnetinternational.org | www.bacnetinternational.org



Why Specify the BTL Mark?

The BTL Mark is a mark of distinction. It provides users with confidence that a product has passed the industry standard BACnet conformance tests conducted by a recognized, independent testing organization and provides suppliers with confidence on product quality and performance, on costs and liability, as well as greater buyer confidence.

How is the BTL Mark Obtained?

Products that have been successfully tested by a Recognized BACnet Testing Organization (RBTO) and successfully received the BTL Certification are eligible to display the BTL Mark as part of the listing process. The BTL Certification Process is administered by BACnet International and oversight is provided by the BTL Working Group.

Upon successful certification, a product can be added to the BTL Listing website, along with its Certificate, PICS and other information. After a product is added to the BTL Listing the manufacturer can use the BTL Mark in relation to that product, according to the BTL Mark usage policy.

What Advantages Does the BTL Mark Provide?

There are benefits of the BTL Mark for both users and suppliers.

Benefits for Users

For users, the BTL Mark indicates that a product has undergone rigorous industry standard testing to validate its BACnet functionality. BACnet is the world's standard for building interoperable solutions, but it only works when products are correctly implemented. When products that are not correctly implemented are purchased, it can cost a lot in terms of system integration time and money.

Reliance on products with the BTL Mark lowers the risk of integration problems and the project delays and cost-overruns that come with them. In addition, the use of products with the BTL Mark provides a solid foundation for future system enhancements and extensions.

Users can search the [BTL Listing of Tested Products Database](#) free of charge to validate products have been Certified and verify a product's BACnet functionality. The service supports searching for specific products as well as browsing through products with different capabilities. In addition, the listing service provides detailed information on the specific tested capabilities of each product.

Benefits for Suppliers

The BACnet specification is large and complex. Even the best development teams can misinterpret some detail of the protocol or introduce a subtle implementation error. The rigorous testing associated with obtaining the right to use the BTL Mark is a powerful methodology for ensuring such errors are found and eliminated before a product reaches the market.

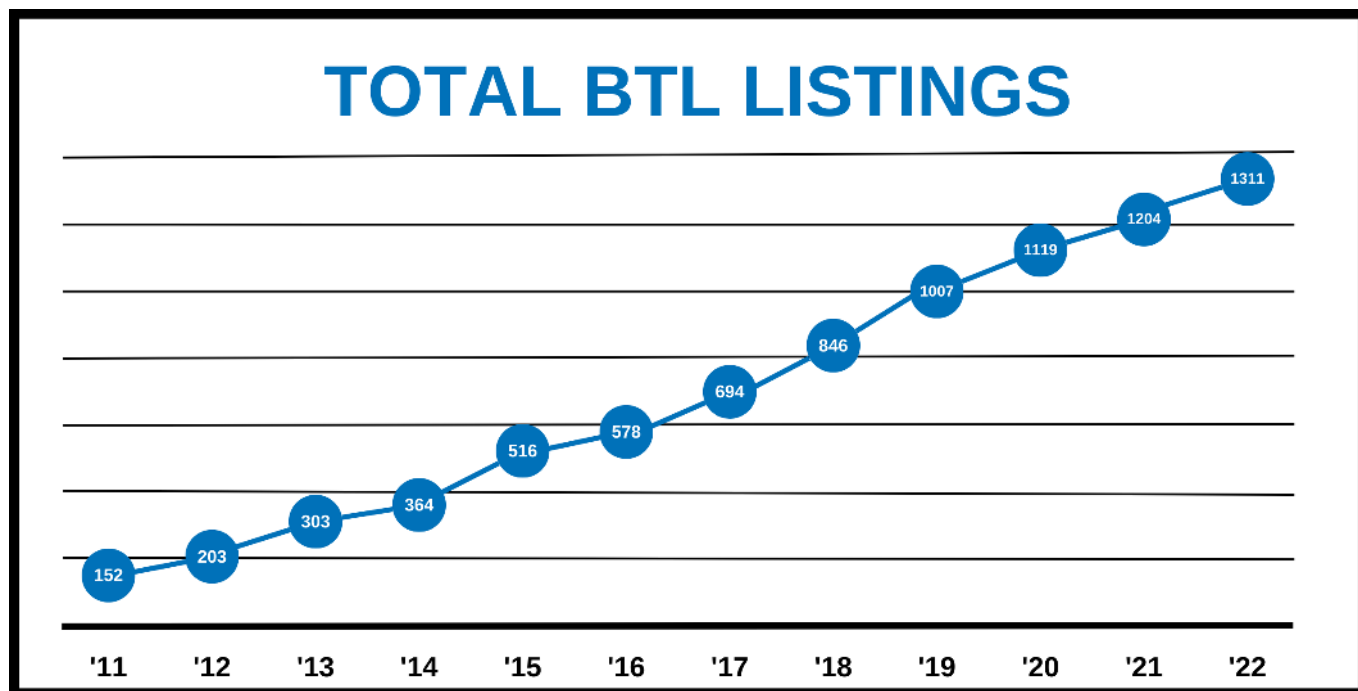

The number of BTL Listings continues to grow.
© BACnet International

Resolving interoperability problems in a multi-vendor environment during BACnet system integration can be expensive and potentially discouraging for customers. In the event of an interoperability problem between a product with a BTL Mark and one without it, a common assumption is the product without the Mark is at fault. Whether it is or not, the burden of finding and resolving the problem tends to weigh most heavily on the manufacturer that has not demonstrated compliance through the BTL Mark program. Earning the BTL Mark reduces the risk of BACnet implementation errors causing interoperability problems and minimizes the associated costs.

Growth of the BTL Mark

In 2018, there was a total of 846 products with a BTL Listing. Just at the 2023 AHR Expo in Atlanta, Georgia, there were 929 BTL Listed products showcased by the various exhibitors on the show floor.

As more and more building owners and control system designers recognize that the use of products that carry the BTL Mark accelerates and lowers the cost of system integration, the requirement for a BTL Mark is becoming more common on specifications. With this trend, along

with the gains provided by compliance testing to suppliers, the number of BTL Listed products continues to grow, and currently stands at over 1,300.

This year marks the 20th anniversary of the BACnet protocol becoming an ISO Standard. There has been much growth in BACnet over this time, both in the evolution of the protocol and its worldwide adoption. The BTL Mark is instrumental in this growth as it enables BACnet interoperability through testing and certification, and contributes to the overall quality of products in the field.

For more information on the Certification process or device testing, visit the BTL website at btl.org.

ABOUT THE AUTHOR

David Nardone focuses his time on membership and trade show management for BACnet International. Prior to joining the association, Dave was in facilities and materials management for over ten years in the medical industry. He is the primary point of contact for BACnet International members, accounts receivable, is a contributing writer/editor, and attends all trade shows on behalf of BACnet International.



David Nardone
Membership & Education Manager
david@bacnetinternational.org | bacnetinternational.org



Need more training or
a refresher in BACnet?
Register for

The BACnet Institute

- On-demand, interactive courses that provide FREE CEUs and PDHs
- Curated library containing over 160 articles, white papers and recorded industry lectures
- Knowledge-sharing forum where questions get answered by BACnet experts



Courses • Resources • Community

Registration is **FREE!**
New users can register by going to
thebacnetinstitute.org

HVAC Integration in Context of Energy Savings

Buildings are responsible for 40% of the world's energy consumption and for 36% of CO₂ emissions. Among all subsystems within the building, HVAC is the most energy-hungry asset. Reducing their energy consumption is a key issue and for that, BACnet control is ideal.

According to statistics from the European Union and the International Energy Agency, the building sector is the most energy consuming vertical, more than industry or transportation. Within buildings, cooling is the fastest-growing application, especially in emerging countries like China, India, Indonesia, Mexico, and Brazil. Every year, over 100 million aircon units are installed worldwide. To meet European's goals, the reduction of energy consumption by HVAC systems is mandatory. The BACnet technology plays an important role to meet this target.

The situation nowadays

The Energy Performance of Building Directive (EPBD) from the European Union sets the legal requirements that commercial buildings shall comply with, to reduce their CO₂ footprint. Those non-residential buildings with an effective rated output for systems for air-conditioning of over 290 kW shall be equipped with a Building Management System (BMS) by 2025, otherwise, those buildings shall undergo regular inspections that include an assessment of the efficiency and sizing of the air-conditioning system compared with the cooling requirements of the building. Typically, a hotel with 70 rooms or an office building of 5 floors has HVAC systems above the threshold of 290 kW. BACnet then, plays the key role in setting up the standards and compatibility with main HVAC brands to make this happen.

The role of the BACnet BMS

The BMS shall be capable of continuously monitoring, logging, analyzing, and allowing for adjusting energy use, benchmarking the building's energy efficiency, detecting losses in efficiency of technical building systems, and informing the facility manager about opportunities for energy efficiency improvement. Additionally, the BMS shall allow communication with connected technical building systems (e.g., HVAC, lighting, fire systems, etc.) and other appliances inside

the building, and being interoperable with technical building systems across different types of proprietary technologies, devices, and manufacturers.

The challenges

The main challenge to integrate HVAC systems into BACnet BMS is the fact that the communication protocols used by the HVAC systems are proprietary. Gateways that connect HVAC systems with the BMS should be developed in close collaboration with the AC manufacturers and should be validated by them to guarantee the proper function with the aircon unit. AC manufacturers also face the challenge to support different control technologies depending on the BMS vendor, building topology, or country of installation.

The trends

Recent trends in the market for energy efficiency are related to improving the air quality, but also allowing the BMS to have a certified calculation of the individual energy consumption that each

AC unit generates.

The results on energy savings and CO₂ emissions

To estimate the energy savings achieved when integrating the HVAC system to a BMS, we take a common split unit as a reference model. According to the AC industry benchmark, a standard split unit consumes 353 kWh per year in cool mode and 1,594 kWh in heat mode, resulting in total annual energy consumption of 1,947 kWh. This means that each million of AC units installed can consume up to 1,7 Twh of energy.

Several HMS customers report energy savings between 20-45% using Intesis AC interfaces in the retail sector. Assuming an average of 30 % energy savings across the different projects, Intesis AC interfaces help to save 509 GWh per year. According to statistics from the European Union, the current power mix of renewables, nuclear power, gas, and coal plants results in 295 grams of CO₂ per generated kWh. Thus the 509 GWh energy savings correspond to 150,000 tons of reduced CO₂ emissions. 🌱

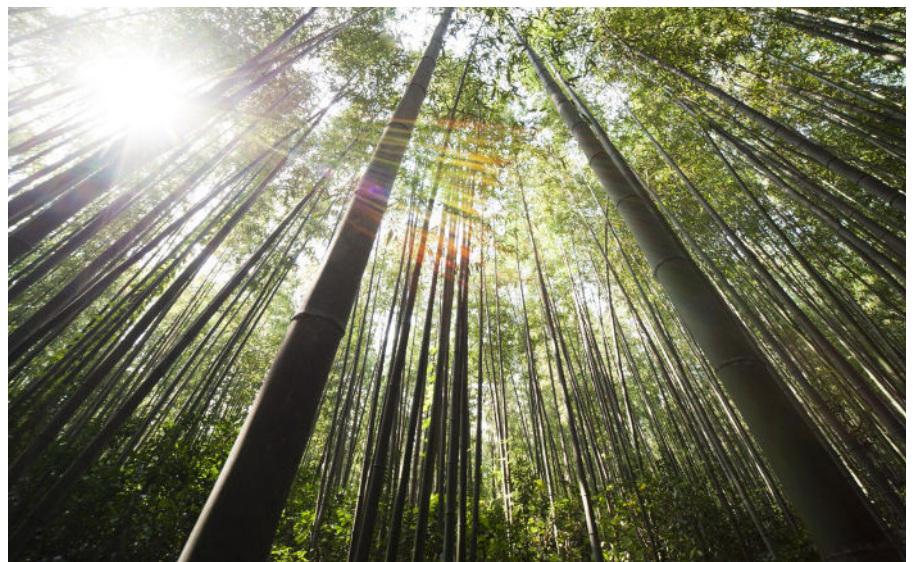

With an average energy saving of 30%, Intesis AC interfaces can save 150,000 tons of CO₂ emissions.

About the Author

David Garcés, born in Bilbao (Spain), is the Managing Director of BU Intesis, HMS' division for building automation. He holds an M.Sc. in electrical engineering and an MBA. David has 20 years of experience in factory and building automation, the last 6 years working for HMS in different roles.



David Garcés Varona
General Manager Intesis | HMS Networks
dga@hms-networks.com | www.intesis.com



Canada's First Zero Carbon Office Building

The Cora Group is a premier developer and manager of Class A office space predominantly within Canada's Waterloo Region. For over four decades, the company has established over two million square feet of space, earning them the enviable reputation as one of the largest developers and managers of commercial, industrial and residential real estate in the Waterloo region.

Situated in the heart of Waterloo's emerging IdeaQuarter is the Cora Group's innovative evol1 building. Engineered and built to attract today's tech-savvy millennial workforce, their goal was to create a comfortable and energy-efficient urban office environment using state-of-the-art sustainable building principles.



© Evolv

Solution

Constructed in accordance with LEED¹ Platinum principles, evol1 wanted to achieve a net positive energy output, generating more energy than it consumes. To achieve this, evol1's building automation system (BAS) needed to successfully integrate, monitor and manage existing heating, ventilating and air-conditioning (HVAC) equipment, as well as ancillary building systems. Additionally, the final solution would need to provide real-time 360° views of all systems while providing facilities staff centralized management from any location.

The Cora Group chose Conestogo Mechanical, Inc. as the local Carrier Controls Expert to meet the controls and BAS objectives for the evol1 project. Conestogo was chosen based on its past reputation with other prominent Canadian buildings, and their ability to design and implement Carrier control solutions.

The installation features native BACnet control of mechanical equipment as well as BACnet integration to various systems throughout the

building. The Carrier i-Vu[®] BAS was installed to provide centralized management of all equipment and systems from a single user interface. Custom 3D graphics were designed to give facilities staff real-time visibility and control from any location. evol1 is a uniquely modern 104,000 ft² building — the first zero carbon building constructed in accordance with LEED¹ Platinum principles and is the first multi-tenant building of its kind in Canada. Developed and managed by The Cora Group, evol1's building goals included:

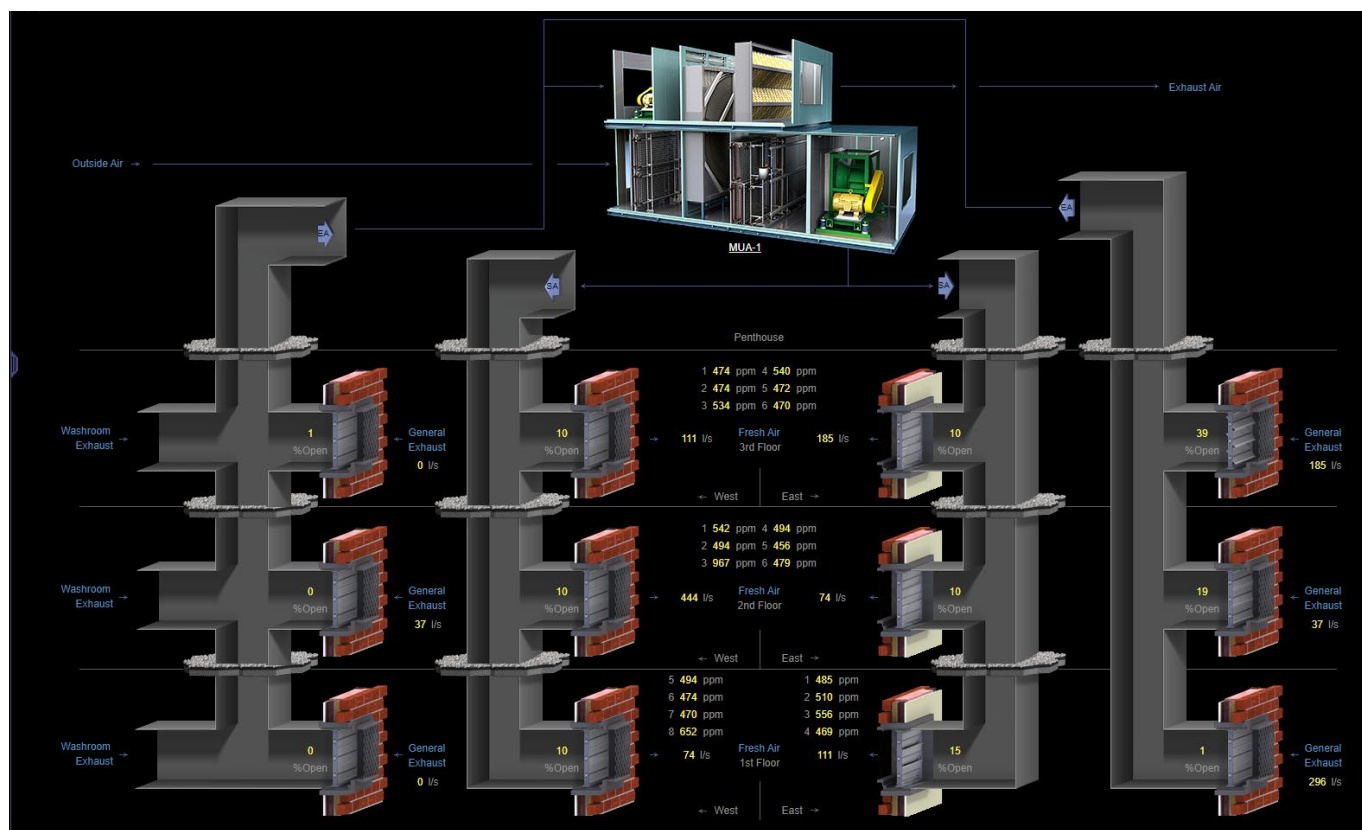

The i-Vu Building Automation System Provides Real-Time Management through a Graphic-Rich User Interface. ©Carrier

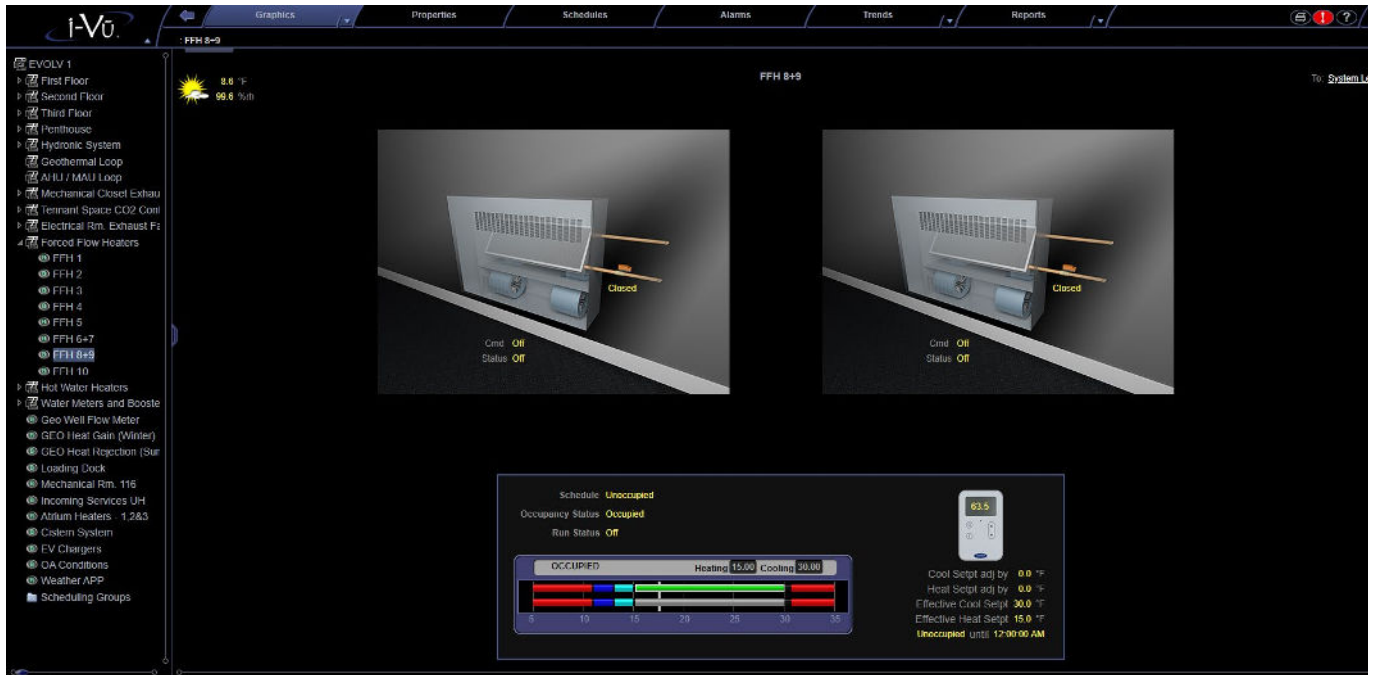

To help meet sustainability goals, custom 3D graphics were created to provide a 360° view of all building systems.

©Carrier

- Installing a non-proprietary, BACnet building automation system
- Selecting a BAS to integrate a wide variety of mechanical and building system components
- Achieving a net positive, zero carbon output facility
- Representing the very latest in building comfort, control and operating technologies

The Cora Group selected Conestogo Mechanical to recommend, design and configure, install, and maintain a complete BAS solution. “We have worked with them before and knew they had the resources,” said Cora Chief Operating Officer, Adrian Conrad. To provide additional peace of mind to the Cora Group, Conestogo had the comprehensive BAS component and engineering support of the local Carrier Enterprise office.

When Conestogo officially came on board approximately two years prior to evol1’s completion, their mandate was to:

- Review the mechanical budget
- Provide value engineering
- Execute a successful BAS solution
- Create a full custom-designed graphics library to dynamically show — in real time — precisely how each monitored component is operating

“From a controls and building automation perspective, evol1 was the most interesting and technically-challenging project that we’ve had to date,” said Kyle Mavin, Conestogo’s HVACR/Controls Lead. “Creating a successful controls and BAS solution for a zero carbon, net positive and LEED Platinum certified building comes with its own inherent complexities. To address this, we integrated all third-party equipment/systems using BACnet IP and BACnet MS/TP.” Mavin said. The Carrier i-Vu® system monitors and controls:

- VRF synchronous electric heat pump chillers
- Solar heating wall
- Separate hydronic loops
- Tenant space CO₂ levels
- Refrigerant leak alarms
- Geothermal open wells
- Solar heating wall and plenums
- Fan coils and condensers
- Hot water heaters and boilers
- Water meters and atrium air handler
- Cistern water
- Electric vehicle charging stations
- Fresh air make-up air unit
- Mechanical room exhaust

In addition, native BACnet controllers including MPC XPs, AppControllers, and UC XPs were installed on various equipment in the building to monitor and control dampers, hot water and chiller water coils, pumps, valves, exhaust fans, vestibule heaters, and the reclaim water system, enabling hundreds of points of information to be transferred from the mechanical equipment into the i-Vu system.

As a result of the precise level of monitoring and control that i-Vu delivers, evol1 generates more energy than it consumes and is the first building to earn the Zero Carbon Building – Design certification by the Canada Green Building Council (CaGBC) and the first-ever Zero Carbon award, also from the CaGBC.

A full graphics library was custom-designed to dynamically show precisely how each monitored component is operating. “With the detailed custom graphics and data we have through i-Vu Pro, our view into evol1’s energy management, resource consumption, comfort and any performance variance is immediate. Creating such an advanced, graphic-rich BAS that delivers precise control to attain extremely stringent sustainability goals was a rare and rewarding challenge. And i-Vu ties it all together.” Mavin concluded. 🌱



Carrier Corporation
 controlsexpertsmarketing@carrier.com
www.carrier.com/ivu

Exemplary Energy Efficiency and Tenant Friendliness Combined



Exemplary energy efficiency and tenant friendliness combined in the new Lisbon World Trade Center.

Inaugurated in September 2022, the new World Trade Center complex is located in Lisbon. It consists of three towers with the following space allocation: 25,000 sqm for offices, 4,000 sqm for retail, 10,000 sqm of outdoor space and 1,000 parking spaces. The WTC is accredited with gold certification in LEED and WELL.

The project was developed with the goal of creating a state-of-the-art technology business hub where well-being is the driver of business motivation and productivity.

A comfortable use for about 3,000 people

“The biggest challenge was to allow tenants to design and build out their own rental space. It was a requirement that the tenants’ room automation had to be compatible with the building envelope and the technology of the common areas. The technical solution for building automation was therefore developed on the basis of the BACnet standard,” explains Pedro Prazeres, project manager at Delta Controls system partner Geoterme. At the heart of the system is Delta Controls’ enteliWEB central building management software. Each floor has a touch screen for operating the lighting and visualizing the current CO₂ concentration as well as the consumption of water, recycled water and electrical energy.

The use of BACnet proved its worth in the project, as it was possible to combine the hardware of several manufacturers in an uniform and powerful building automation solution.

Intelligent room automation from Delta Controls

On some floors, Delta Controls’ intelligent room automation with the O3 hub is used to control the air conditioning of offices and open-plan spaces. Room occupant interaction with building automation is possible in certain rooms via the O3 app using a smartphone.

The entire building envelope is glazed and equipped with motorized blinds including EnOcean modules. These can be optimally integrated and made accessible in BACnet/IP via the O3 hubs with integrated EnOcean gateway distributed throughout the office space.

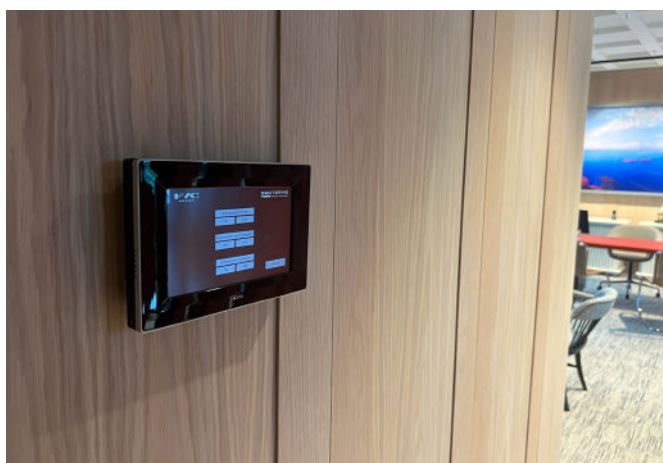

User-friendly room operation by Delta Controls. © Delta Controls Germany

The most important lighting circuits are implemented in DALI lines and integrated into the building automation. A daylight control system based on the measurements of the O3 hubs ensures optimal lighting of the work areas with the greatest possible use of natural sunlight.

Major HVAC systems include the main ventilation system and chilled and hot water generation by two chiller/heat pump groups. Several pump groups provide the distribution of cooling and heating. The building automation system decides on the best possible configuration for chillers and heat pumps based on demand.

Use of rainwater and electricity generation with photovoltaics contribute to sustainability. Centrally collected rainwater is distributed separately and used for toilet flushing. A photovoltaic system, used to generate electricity, is connected to the building automation system for monitoring and evaluation.

In the final stage, the building automation system comprises approx. 800 BACnet devices from Delta Controls and other manufacturers. The number of data points is approx. 18,000.

The goal of creating a place that combines physical and emotional well-being with practical solutions for sustainability and digitalization has been exceeded.



Delta Controls Germany GmbH
sales@deltacontrols.de
www.deltacontrols.de

Delta[™]
CONTROLS
A Delta Group Company

Water to Air Solutions Applied to Skyscrapers with BACnet

Nowadays, skyscrapers are commonly perceived to represent power and ambition, not just by large corporations but the entire society. More and more new iconic skyscrapers can be found in large cities of many countries.

One of the obvious features of this type of building is the very small horizontal dimension in comparison with the building height. As a consequence, access to the outdoor space is very limited and plant rooms often have to be located inside the building.

Water-to-Air VRF Solutions

In comparison with air-to-air systems where the outdoor units have to be installed outside, water-to-air VRF systems use water as condensing fluid and the outdoor unit can be installed indoors. This characteristic can make it suitable to use in skyscrapers as far as a primary water loop is available to use.

This solution has the same advantages and benefits as the air to air VRF system. It can be used for not only space heating and/or cooling, but also generating domestic hot water (DHW) via hydro kits.

BACnet: most widely used communication protocol in building automation

All this technical equipment must be 100% integrated despite the manufacturer. For instance: water pumps, valves, drives, chillers, thermostat, PLC or HVAC integration must be inter-connected for full operation of the building. In addition, BACnet, as one of the main communication protocols used in building automation and control networks, is commonly used in skyscrapers. It works well in combination with BACnet MS/TP serial lines from field installation, BACnet/IP, and highly integrated gateways to connect to the communication network of the Building Management System (BMS).

Q22 skyscraper in Poland

Q22 is one of the most widely recognized skyscrapers in the city of Warsaw in Poland. Located in the financial business centre of the city, this skyscraper building is used as office

space, including part of the building being rented out to other businesses as offices.

The building provides comfort to the building occupant based on the latest VRF technologies and numerous other building services that were dedicated to make the building comfortable, functional and efficient.

Conclusion

In conclusion, LG's water-to-air VRF systems are suitable to use in skyscrapers to provide energy efficient solutions for heating and cooling with individual zone controls for the benefit of the building occupants.

Considering the many building services installed in large construction projects such as skyscrapers, a full integration of every subsystem into the building's BMS is often required for the sake of easy operation and maintenance. This includes but not limited to the following systems: lighting, fire alarms, security, motion detectors, CCTV, control access, energy measurement/

smart meters, lifts, HVAC systems, information and communications technology (ICT). As one of the most widely used communication protocols for building automation, there is no doubt, BACnet will continue to play an important role in the integration of various building services into the BMS.



LG Multi V Water: VRF Water-to-Air production unit.



LG Wall mounted air conditioners units: indoor offices.

© LG Electronics



LG Electronics European Business
www.lg.com

Flexible, Sustainable Solutions for the Working World at Axel Springer



© Nils Koening

The new Axel Springer building in Berlin is a symbol and accelerator of the publishing group's cultural transformation. Efficient building operation and comfortable indoor conditions are ensured by the building automation and building management solution from SAUTER.

Digitalization has disrupted the media and entertainment industry like no other. Axel Springer has been one such company, driving this structural change consistently and successfully in-house. Overall, the group now generates more than 70 percent of its revenues from digital businesses and operates in over 40 countries.

The headquarters of the media and technology company is in Berlin. The new build, ceremonially opened in October 2020, is an addition to the Axel Springer quarter and an absolute eye-catcher. The interior is no less impressive either. Besides traditional office spaces and television studios, it features large-scale work areas with an atrium 45 metres high, and interconnected, terraced stories. The mainly open-plan layout

offers more than 3,000 employees space for interaction.

Building technology requirements for modern workspaces

SAUTER Germany was tasked with controlling, regulating and monitoring the technical building facilities. Systems are constantly monitored and optimized through a service and maintenance contract with SAUTER. An extremely busy work environment, the wide-ranging use of the interior – from TV studios to the auditorium and individual offices – as well as the architecture itself, all meant that the building automation had to fulfil quite specific needs. Flexibility, efficiency and sustainability were of key importance. The

Some of the spotlights are located at a height of over 35 m in the expanded metal ceiling of the large atrium and it was a technical challenge to assign the right spotlights to specific brightness sensors.

control system with dimming function responds to the presence of people and brightness. The lighting of the smart workspaces is thus highly energy efficient. A vast array of components and equipment were installed – 800 system distributors, over 850 BACnet devices, 2,600 DALI brightness sensors (and more than twice as many DALI lamps!) and 55 mechanical equipment rooms. The ventilation, heating and cooling systems thus run at maximum efficiency and equipment is controllable segment by segment. Ceiling mounting in the open area was not possible. Sensors and touch operating units were therefore fitted on metal pedestals.

Smart solutions supporting energy efficiency

The building management system SAUTER Vision Center permits visualization, monitoring, operation and logging of the building technology across systems. It is assisted by access to 100,000 data points. A customized programme flexibly regulates the large spaces of the new Axel Springer building. Segments are grouped into imaginary single rooms and can thus be operated separately.

The integrated energy management system saves resources during operation and optimizes the maintenance intervals. It also features an automatic SAP export function for energy cost billing, as requested by the customer. The innovative cooling method of the building is controlled by means of weather forecast data. Changeovers take place overnight so that a pleasant indoor climate awaits employees and visitors the following morning. 



SAUTER Head Office
info@sauter-controls.com
www.sauter-controls.com

New to the BACnet International Family



BACnet International is the global organization that encourages the successful application of BACnet through interoperability testing, educational programs and promotional activities. BACnet International complements the work of other BACnet-related groups whose charters limit their commercial activities.

BACnet International community membership includes a who's who list of top tier companies and industry professionals involved in the design, manufacture, installation, commissioning and maintenance of control and other equipment that use BACnet for communication.

We are proud to welcome the following new members to BACnet International.

New Silver



Control Concepts

Control Concepts designs and manufactures digital scr power controllers for the semiconductor, solar, glass, and other manufacturing sectors that require precision power control. Their technical expertise includes low voltage AC, analog, digital, magnetics, and power electronics design.

8077 Century Blvd.
Chanhassen, MN 55317
United States

www.ccipower.com

Member News

BACnet International would like to congratulate the following companies on their strengthened commitment to the BACnet protocol and increasing involvement in the BACnet community. As part of these actions they have moved their membership to the Gold tier. We thank them for their continued support and look forward to many more years of collaboration.

Silver to Gold



Accuenergy (Canada) Inc.

Accuenergy (Canada) Inc. was formed in 1998 and has since then delivered power metering solutions to over 170 countries worldwide. As a trusted global manufacturer specialized in advanced energy measurement and management technology, they ensure their solutions are designed for quality, accuracy, performance, and cost-effectiveness. Their growing global footprint expands to offices in Toronto, Los Angeles, Pretoria, and Beijing.

22 Howden Road
Toronto, ON M1R 3E4
Canada

www.accuenergy.com

Silver to Gold



Eaton Corporation

As a global power management company, doing business in more than 175 countries, Eaton helps their customers solve their greatest power challenges through their electrical, aerospace, hydraulic and vehicle products and services. For more than 100 years, Eaton's teams have helped people work more safely, be more energy efficient and live more sustainably.

1000 Cherrington Parkway
Moon Township, PA 15108
United States

www.eaton.com

Better indoor air quality with Reliable Controls

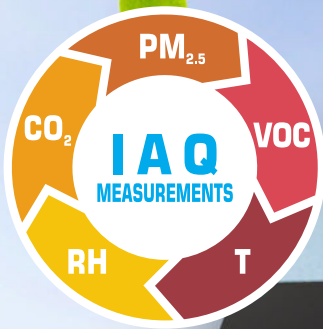

MACH-ProView™ LCD controller



SMART-Sensor™ EPD

According to the World Green Building Council, we spend 90 percent of our time indoors. Given that statistic, it's clear the quality of the air we breathe in buildings can dramatically impact our health and well-being. At Reliable Controls we believe sustainable buildings are a key component to reducing the health and environmental impacts of indoor and outdoor air pollution. Learn more reliablecontrols.com/IAQ



Reliable[®]
controls

New BACnet Cybersecurity Acceleration Program

“People, process, and technology” have long been cited as the three pillars of IT, and, by extension, BACnet cybersecurity.

The very successful BACnet Secure Connect Interoperability Acceleration Program, hosted by BACnet International, focused on educating those tasked with developing more secure building automation products, such as product designers and developers, on the technology that is BACnet Secure Connect (BACnet/SC). Through this program, BACnet International delivered a reference implementation of a BACnet/SC Hub and Node as well as a system test bench to accelerate not only product development but testing and certification of those products.

The next phase of BACnet International’s BACnet security program aims to extend education beyond manufacturers to include integrators and owners. Opportunities to learn about the processes and policies around certificates, certificate management and overall system management will be offered. This knowledge will be invaluable during the initial deployment of a BACnet secured system and provide insights into maintaining and enhancing the system over its lifetime.

For manufacturers, this new program will provide technical guidance to assist in better understanding certificates and certificate management requirements for BACnet secured systems. The program will also deliver reference tools for certificate management.

This new BACnet Cybersecurity Acceleration Program will strengthen the three pillars of BACnet cybersecurity. It will provide opportunities for a wider audience to learn about the processes, policies, and the technology around BACnet cybersecurity, while providing reference tools and support to assist manufacturers in delivering the next set of tools to help move the industry forward. 

For more information visit:

www.bacnetinternational.org/cybersecurity



Test your BACnet products in a neutral and friendly environment and have the opportunity to improve your BACnet implementation and testing methods!

BACnet INTEROPERABILITY WORKSHOP

October 3rd - 5th | Durham, NH
bacnetinternational.org/plugfest

BTL CERTIFICATION

Your Best Path to BACnet Interoperability



BACnet is the world's standard for interoperable building automation solutions, but it only works when products in a system are correctly implemented.

BTL Certification provides customers, end-users and building owners/operators with assurance that a product has successfully undergone industry-standard testing conducted by recognized, independent testing organizations.

It also provides users with confidence on product quality and interoperability in a multi-vendor environment, and can help minimize costs and risks associated with system integration.

For suppliers, BTL testing is a powerful methodology for finding and eliminating implementation errors before a product reaches the market.

Products that have successfully passed conformance testing are eligible for a BTL Certification and added to the BTL Listing. Only BTL Listed products may use the BTL Mark.

The BTL Mark is a mark of distinction and has come to represent a high level of quality and conformance. It is becoming commonplace for specifications to require a BTL Mark in order to be eligible to bid on a project.

To find out more about testing, or to view the list of tested products, visit btl.org.

There are over 1300 products in the BTL Listing of Tested Products Database.



BACnet Testing Laboratories
btl.org
info@bacnetinternational.org
+1-770-971-6003

BACnet International at the 2023 AHR Expo

The AHR Expo returned to Atlanta, Georgia with strong attendance and exhibitor numbers. According to show management, there were 42,794 verified visitor and exhibitor personnel, and 1,779 exhibit booths. These numbers were close to the largest AHR Expo, which was in Orlando in 2020, so it seems the show is returning to pre-pandemic numbers.

BACnet International had a strong presence with a booth in the Building Automation pavilion, highlighting advances in BACnet product testing and certification through BACnet Testing Laboratories (BTL), the latest in free educational resources through The BACnet Institute (TBI), and the benefits of membership with BACnet International. This year marked the largest group of corporate member companies exhibiting (82), and the largest number of BTL Listed products being represented (929). Hard to believe that's more products at the show than the total amount of listed products in 2018 (846)!

Once again, BACnet International hosted an education track which featured four well attended presentations. These were:

- The Hitchhiker's Guide to BACnet, presented by Andy McMillan, BACnet International
- BACnet 101, presented by Edward Tom, Yaskawa America
- BACnet-centric Guide Spec, presented by Grant Wichenko, Appin Associates
- Deploying BACnet Secure Connect, a panel discussion moderated by Andy McMillan and including Stephen Holicky

(Tridium), Ken Gilbert (Automated Logic), Carol Lomonaco (Johnson Controls), Zach Netsov (Siemens), and Dave Robin (BSC Softworks).

All of these sessions were recorded and are available in the Resources section of [The BACnet Institute](#). We were pleased to welcome corporate member volunteers in the booth who spoke with visitors, answered questions, and promoted the protocol. Volunteering in the BACnet International booth is a wonderful way to network with industry peers, spend time with BACnet experts,

and share the benefits of BACnet as well as your company specialties.

Next year, at the 2024 AHR Expo, BACnet International's booth (S6100) will be double in size. We look forward to seeing everyone in Chicago!

Panel discussion on BACnet Secure Connect (BACnet/SC)
© BACnet International



The BACnet International booth highlighted BTL and TBI as well as updates on BACnet cybersecurity.
© BACnet International



EXPAND YOUR BACnet KNOWLEDGE



Courses • Resources • Community



TBI continues to grow. There are now over 6,000 registered users, and articles and presentations are continually being added to the Resources section, providing many materials to help you and your colleagues stay connected and engaged. A better-informed community brings positive change, so take a moment to expand your knowledge of BACnet as well as encourage others!

Popular BACnet International Trade Show Session Recordings

BACnet International has presented an Education Track at the past several AHR Expos. Most show sessions were recorded and have been uploaded onto TBI for you to experience either again or for the first time, including the **four presented at the 2023 AHR Expo**. Those sessions include “The Hitchhiker’s Guide to BACnet,” “BACnet 101,” “BACnet-centric Guide Spec,” and “Deploying BACnet Secure Connect.”

Multi-Level and Multi-Lingual Materials in Resources

With over **160 articles and presentations** focused primarily on BACnet, the TBI library offers a variety of topics, in different languages and expert levels. Among the top articles accessed are “An Introduction to BACnet,” “Deploying and Maintaining BACnet Systems in Today’s Networks,” “LED Lighting – An Automation Armageddon,” “Cybersecurity for BACnet BAS Webinar,” and many more. Also check out the bi-lingual “Device Profile Families Facilitate Planning” article by Bernhard Isler. Check back often, since articles continue to be added.

Interactive Courses Fit into Your Schedule, and Offer FREE CEUs & PDHs!

There are three interactive courses available on TBI, and, as an IACET Accredited Provider, BACnet International offers **FREE Continuing Education Units (CEUs)** upon completion of each course. Professional Development Hours (PDHs) are also available upon completion. The three courses are:

- BACnet Basics - a comprehensive course that covers all the basics of BACnet. Don’t know anything about BACnet or need a refresher? This is an excellent course to take.
- The Facility Manager’s Guide to Building Automation Systems. You don’t need to be a facility manager to take this course, in fact, this course is incredibly beneficial to anyone who works in the building automation industry.
- BACnet Device Profiles - introduces learners to the various BACnet device profiles and explains the role of each in the building automation. It also shows the learner how various profiles can be combined in a single device and explains the rules behind the combinations.

A Community Forum to Get Your BACnet Questions Answered

The BACnet Community Forum is an interactive environment that offers knowledge-sharing and provides an opportunity for users to submit BACnet-related questions to be answered by a panel of experts in the BACnet industry.

Participants in the forum can submit new discussions, reply to discussions, and receive updates of peer posts through email subscriptions. Answers to submitted questions are posted in the forum, which can then be searched by all registered users.

Past discussions submitted through the Cornell University BACnet-L email list server are also included.

Visit TBI!

If you haven’t visited The BACnet Institute recently, you definitely should! AND, remind your colleagues to do so as well! To access all of these resources, or to sign up for a FREE account, visit thebacnetinstitute.org. 

BACnet Testing Laboratories (BTL) Testing Updates

BTL Testing and BTL Test Package Information

A BTL Certification indicates that the BACnet Stack of the product has successfully passed rigorous industry standard testing and demonstrates that the device correctly implements all of the BACnet functionality it contains as governed by ASHRAE standard 135. The BTL Listing, the BTL Certificate of Conformance, and the right to use the BTL Mark are the three elements that indicate a product has passed the testing and achieved BTL Certification.

The BTL Working Group defines the BTL Test Plan and governs the testing. The BTL Test Package and BTL Testing Policies are published on the BTL website: btl.org/testing-documentation.

New BTL Test Package 23.0

BTL Test Package 23.0 was published December 22, 2022. This test package includes testing up through Protocol Revision 23 of the BACnet standard (ANSI/ASHRAE 135-2020 plus addenda: cd).

Test Package Transition Period Following Publication of Test Package 23.0

The BTL Working Group has established a transition period for BTL Test Package 23.0. During the transition period, vendors with products claiming Protocol_Revision 20 or less may test with either Test Package 20.0.1 or with BTL Test Package 23.0. Products claiming Protocol_Revision 21 or greater must test with BTL Test Package 23.0. The transition period ended March 31, 2023. As of now, all products entering BTL Testing must test with Test Package 23.0.

BACnet Secure Connect Resource Available Free to the BACnet Community

This **BACnet Secure Connect (BACnet/SC) Reference Stack** was developed as part of BACnet International's BACnet/SC Interoperability Acceleration Program. It is available to anyone in the BACnet Community for free. You can download it here: sourceforge.net/projects/bacnet-sc-reference-stack

BACnet International conducted three educational webinars as part of the program. These **BACnet/SC Webinars** were recorded and uploaded to the BACnet International YouTube page in September 2021 and can be found here: youtube.com/c/BACnetInternational

For additional information on BACnet Secure Connect resources, visit the BACnet International website at bacnetinternational.org/bacnet-sc/

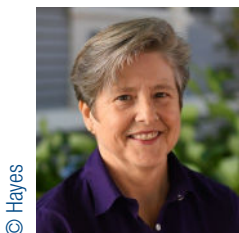
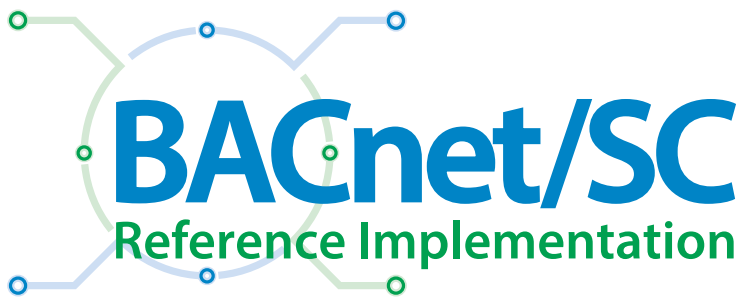

Emily Hayes
BTL Manager, Certifications and Listings
Manager and BTL Working Group Chair
btl-manager@bacnetinternational.org | www.bacnetinternational.org



ABOUT THE AUTHOR

Emily Hayes began work with BACnet International in 2014 as BTL-Coordinator, coordinating BTL Testing at the BTL Lab. In 2017, Emily took over leadership of the BTL Working Group as chair. Additionally, she led the transition from the BTL Listing Program to the BTL Certification Program. She became BTL Manager in January 2019.

Emily maintains professional membership in the Project Management Institute (PMI), North Carolina Chapter of PMI (NCPMI), and Institute of Electrical and Electronics Engineers IEEE.

Emily has a BEE from Auburn University and an MSEE from Duke University. She has maintained a Project Management Professional (PMP) Certification since 2010.

Corporate Membership Benefits

Corporate membership in BACnet International provides unique and valuable benefits to manufacturers and service providers in the controls, building automation and energy management industries. Its information services make it easy to keep up with the growth and evolution in the industry and with BACnet technology. BACnet International membership enhances a supplier's credibility with potential customers and partners while providing a variety of opportunities for exposure and promotion. Corporate membership also gives manufacturers access to deep discounts on product testing, BTL Certification and a variety of third party development tools.

Discounts on Tools, Testing and Certification

- 50% discount on hourly BTL testing rate for Platinum, Gold and Silver members when using the BTL Lab
- Options for expedited testing when using the BTL Lab
- Included and/or discounted annual BTL Certified Product Listings
- Discounts on event registration for your whole team, including for the annual BTL PlugFest interoperability event
- License to use BACnet International developed test-related tools
- Discounts on pre-testing tools to help reduce costs and time in the BTL Lab

Information Services

- Corporate Update newsletter keeps your team up to date on important developments related to the BACnet standard, including proposed changes, new releases and corrections. It also alerts your team to the availability of marketing and promotion opportunities.
- Cornerstones monthly newsletter provides your team with timely information on new BACnet case studies, the latest products from member companies, educational resources, and highlights of global events.
- BACnet International Journal provides more in-depth articles on BACnet technical issues, application examples and industry insights. The Journal provides your team with additional marketing and promotional opportunities through authorship and advertising.

Marketing & Promotion Opportunities

- Display of company logo on the BACnet International website and in newsletters
- License to use the BACnet International "Member of" logo on corporate website and marketing material
- Opportunity to author and present BACnet content through print, electronic, in person and social media
- Discounts on advertising in the BACnet International Journal
- Trade show representation, participation, and conference presentation opportunities

BACnet Community Engagement

- Help the industry continue to move toward interoperable products based on BACnet, the global standard for building automation.
- Network with manufacturers, suppliers, users, consultants, and students by participating in annual events and trade shows.
- Support the work of BACnet International in maintaining the global BTL Product Certification Program through the BACnet Testing Laboratories (BTL) and education services of The BACnet Institute.
- Enjoy the "halo effect" gained from industry recognition and credibility gained from being a BACnet International corporate member.
- Get recognized by authoring articles, and volunteering for committees or Board of Directors service.

For more information:

Contact Membership and Education Manager David Nardone at david@bacnetinternational.org.

NEW BTL-LISTED PRODUCTS, September 2022 – February 2023

Manufacturer	Product Name	Model
75F	HyperStat	7X-HS-C2W-X
Accuenergy (Canada) Inc.	AcuRev 2100 Series Multichannel Multifunction Power and Energy Meter	AcuRev 2110, AcuRev 2120
Accuenergy (Canada) Inc.	Acuvim II Series Multifunction Power and Energy Meter	Acuvim II, Acuvim IIR, Acuvim IIE, Acuvim IIW, Acuvim IIBN, Acuvim IIX
Automated Logic Corporation	OptiFlex™ BACnet Building Controller	OFBBC OFBBC-NR
Badger Meter Inc	Flow Meter	Dynasonics TFX-5000 Flow (DQ)
Badger Meter Inc	Thermal Energy (BTU) Meter	Dynasonics TFX-5000 Energy (DR)
BDR Thermea Group B.V.	GTW-21	7756023
Computrols	Serial Connector	Serial Connector
Delta Controls	V4 Product Platform	eBMGR-2, eBCON-2, O3-DIN-CPU, O3-DIN-SRC, Red5-PLUS-ROOM, Red5-EDGE-ROOM, Red5-x-y where x is PLUS, EDGE, or FIELD
Fr. Sauter AG	Smart Actuator	ASM115SAF232, AVM115SAF232, AKM115SAF232
Fr. Sauter AG	VAV Kompaktregler BACnet M	ASV205BF132E, ASV215BF132E, ASV215BF152E, ASV215BF152D
Honeywell International	Edge Control Series	ECGx1-x2x3x4 where x1 is 100, 200 or 500 x2 is C or P x3 is E or R x4 is number 0-9 or blank
Honeywell International	Edge Control Series	ECx1x2-x3x4x5 where x1 is C, D or E x2 is 100, 200 or 500 x3 is C or P x4 is E or R x5 is number 0-9 or blank
Honeywell International	Honeywell Smart Sensor	TR50-5N, TR50-5D, TR50-3N, TR50-3D, TR50-5N-B, TR50-5D-B, TR50-3N-B, TR50-3D-B, TR50-5N-BW, TR50-5D-BW, TR50-3N-BW, TR50-3D-BW

Manufacturer	Product Name	Model
Hysine Controls	BCU/BLC/ELV series programmable logic controller	<p>BCU-x1 where x1 is 941, 630, 940, 860, 843, 1644, 1600, 16160, 1666, 8253, 8800, 8860, 8865, or 420</p> <p>BLC-x2 where x2 is 1040, 1043, 1650, 1656, 1600, 621, 310, 54EH, 32EH, 32E, 24E, 2060E, or 621E</p> <p>BVC-442, BVC-442-P, BVC-SD, BVC-SD-P,</p> <p>BCX-x3 where x3 is H416, H616, H816, H1016, H1216, H620, H820, H1020, H1220, M416, M616, M816 or E466</p> <p>MGP-x4 where x4 is 1102B, 1103B, 1104B, 1105B or 1106B</p> <p>BR-50, BR-10 ELV-x5 where x5 is 410P, 620P, 1050P, 1053P, 1550P, 1030P, 1032P, 1633P, M16A4, M16A6, or M16A8</p>

BACnet Communicating Thermostats

Models for Staged & Modulated Heating/Cooling & Heat Pumps Are Available

The BASstat BACnet-compliant wired or wireless communicating thermostats ensure effortless integration into BACnet/IP (Wi-Fi) or BACnet MS/TP (EIA-485) networks.

- Resident Space Sensor
- Remote Temperature Sensor Input
- Energy Saving Input
- 0-10V Analog Heating and Cooling Outputs
- Single-Speed Fan Output
- Digital Display with Graphical Icons of Operation



BASstat

CONTEMPORARY CONTROLS®

Providing Solutions to Your Automation Needs

+1 630-963-7070 • info@ccontrols.com

Learn more at www.ccontrols.com/basstat

NEW BTL-LISTED PRODUCTS, September 2022 – May 2023

Intesis (HMS Industrial Networks, SLU)	Intesis BACnet Server 700 Series	Modbus to BACnet IP & MSTP, KNX to BACnet IP & MSTP
Lennox International Inc.	Lennox CORE Unit Controller	106519
Quantum Automation	iCON-1400 Programmable DDC	iCON-1400PB
SE-Elektronik GmbH	BACnet Advanced Application Controller M-DDC	MTC FCU-01, MTC FCU-02, UltraSafe, MTC CB, MTC CB-HV, MTC CB-LI, MTC RES-01
Siemens	APOGEE PXC7.A and PXC4.A Automation Station	PXC7.E400.A
Siemens	APOGEE PXC7.A and PXC4.A Automation Station	PXC7.E400.A, PXC4.E16.A
Siemens	Climatix	POL908.00, POL904.00
Trane	Tracer® EnsembleTM	Tracer® EnsembleTM

Calendar of BACnet International Events

2023	Event	Location
May 23 – 25, 2023	LightFair	New York, NY
October 3 – 5, 2023	PlugFest Interoperability Workshop	Durham, NH

Journal of Building Automation 23

The Journal of Building Automation published by BACnet International is a global magazine for the building automation industry. Experts, practitioners and professionals show the way through articles, updates, developments, case studies, and news on the BACnet protocol as well as the wider building automation industry as a whole. Special attention is given to members and activities of BACnet International.

Online Distribution

The Journal of Building Automation is posted to www.bacnetinternational.org and distributed to all members.

Editor

TEMA Technologie Marketing AG
Hans Symanczik
Responsible according to the press law
Aachener-und-Münchener-Allee 9
52074 Aachen, Germany
Phone: +49-172 4160537 | Fax: +49-241 88970-999
URL: www.bacnetjournal.org

Board of Directors

Andy McMillan, President and Managing Director,
BACnet International
Brad Hill, Chair, Honeywell International
Paul L. Bartunek, III, Vice-Chair, ABB
James Burke, Johnson Controls
Raj Jayaraman, Burton Medical
Erica Johnson, QA Cafe
Todd Lash, Siemens
Raymond Rae, CopperTree Analytics
Dennis Swoboda, Blue Ridge Technologies
Michael R. Wilson, Nylite Software

Publisher

BACnet International
2900 Delk Road
Suite 700, PMB 321
Marietta, GA 30067
Phone: 770-971-6003 | Fax: 678-229-2777
info@bacnetinternational.org

Advertising

TEMA Technologie Marketing AG
Phone: +49-241-88970-810 | Fax: +49-241-88970-999
E-mail: sistemich@tema.de

Picture Credits

BACnet International, TEMA AG and specified companies

Copyright

© BACnet International 2023 – Further editorial use of articles in Journal of Building Automation is encouraged with reference to the source. Please send a specimen copy to publisher, or if published online, send the URL via email to info@bacnetinternational.org.

Important Legal Information

The Client is fully responsible for the content or legality of any third party materials supplied and the final published form and usage of these materials; in print, electronic, online etc. The Client is responsible for ensuring that the rights of third parties by publishing in print, electronic, online etc., or any other form of media are not affected. It protects the Contractor, if necessary, against any and all claims which are made by third party claimants. The Client indemnifies the Contractor free of any claims of copyright infringement. The Contractor is not obligated to check any orders and whether the rights of any third parties are affected by it.

BACnet™ is a trademark of the
American Society of Heating, Refrigerating
and Air Conditioning Engineers, Inc. (ASHRAE)

JOURNAL OF **BUILDING AUTOMATION**

A PUBLICATION BY:

